

ENGEL and CANTONI Moulds present

the Injection Blow Moulding Process (IBMP)[®]



high production flexibility
integrated one process
energy saving



I.B.M.P. The smart approach to Injection blow moulding





Injection Blow Moulding Process produces finished bottle container in almost all thermoplastic materials with a full automatic cycle in various capacities and weights.

The system can work with different numbers of cavities, and the output is relatively high due to the capacity of the system which performs the injection and the blowing in overlapping, and the ejection of the finished part in combined stages.

IBMP is a mono block for injection blow moulding with perfect heat distribution, indispensable for obtaining perfectly balanced containers or bottles without marked split lines or flashes.

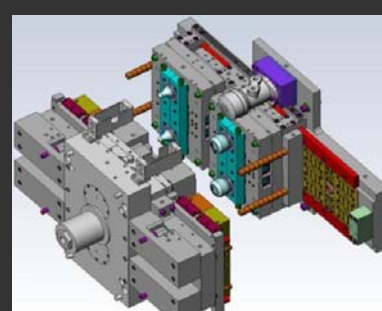
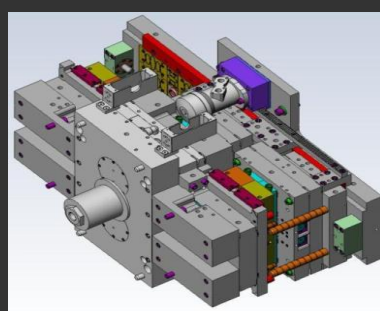
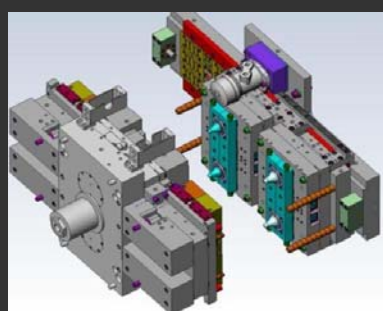
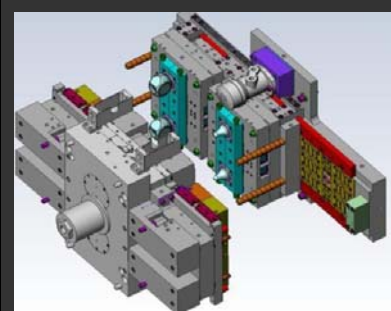

Overview:

Injection Blow Moulding Process has been created to be used mainly in the cosmetic and pharmaceutical field and in food and beverage where the blown container's wall is not required to be very thin.

CANTONI's injection blow molding system is used preferably where the B-orientation during blowing process is not required, the option of the B-Orientation could be included if needed.

Materials:

PET
PC
PE
PP

Products:

Wide mouth containers
Bottles
Jars



Advantages:

less capital investment
higher flexibility
less down time and maintenance
energy efficient drive concept
less wastage
easier quality control
easier shape/format change
lower air pressure requirement
no need of preforms storage
small foot print



Better quality of the injected Preform as there are no limitation to the clamping force
Tiebarless machine
Wide and free accessible mould area
Freedom for automation (Horizontal movement In/out of the mould)



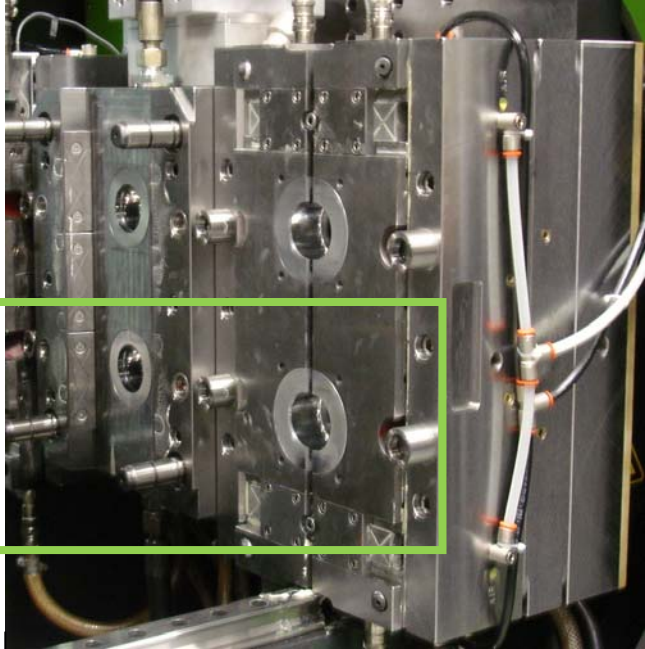

Very fast format / shape change !

*It's Smart
It's Simple
It's Flexible
It's Just Unique*

ENGEL
be the first.



ENGEL packaging
ENGEL Austria GmbH
Ludwig Engel Strasse 1 - A-4311 Schwertberg
tel: +43 (0)50 6200 | fax: +43 (0)50 6203009
e-mail: sales@engel.at
www.engelglobal.com

CANTONI S.r.l.
Via Nazionale 154 - 23821 Abbadia Lariana (LC)
tel: +39 0341 700233 | fax: +39 0341 700235
e-mail: info@cantonil.biz
www.cantoni.biz